

## FEATURES

- High Performance Scientific Camera
  - Hamamatsu S11501 Sensors
  - 1024 x 122 active pixels
  - 24  $\mu\text{m}$  x 24  $\mu\text{m}$  pixel size
  - QE at 1000nm: ~43%
- Integrated TE Cooling
  - -15  $^{\circ}\text{C}$  from 20  $^{\circ}\text{C}$  ambient
  - Hermetically sealed
  - Temperature controlled to  $\pm 0.1$   $^{\circ}\text{C}$
  - Air cooled
- Integrated Digital Signal Processing
  - Utilizes [MityDSP](#) technology
  - Can be customized for application specific processing
- Interface Options
  - USB 2.0
  - 100 Mbit Ethernet
- Programmable General Purpose I/O
  - Use as trigger inputs or drive as shutter / frame strobes

## APPLICATIONS

- Embedded Instrumentation
- Low Light Imaging Applications
- Raman Spectroscopy
- Portable Scientific Instrumentation
- Astronomy



Figure 1: MityCCD-H11501 with Standard Body

## DESCRIPTION

The MityCCD-H11501 family of cameras integrates thermoelectrically cooled high performance CCD sensors suitable for scientific instrumentation with digital signal processing (DSP) capabilities.

An embedded camera rich in features, MityCCD is ready for stand-alone applications. A simple block diagram of the MityCCD camera is illustrated in Figure 2. By integrating a floating point DSP and field programmable gate array into the camera electronics, the MityCCD camera provides the capability to embed application specific code (binning patterns, post processing algorithms, etc.) into a delivered instrument.

The MityCCD uses standard high speed interfaces including 100 Mbit Ethernet and USB 2.0 and eliminates the need for custom interface cards or electronics to a display PC, allowing the use of laptop devices, embedded computers, or (via Ethernet) remote display machines.

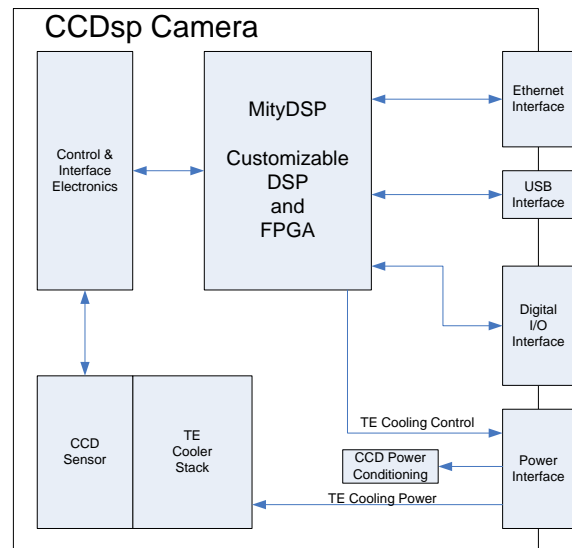

Figure 2: MityCCD Block Diagram

## TECHNICAL SPECIFICATIONS

A summary of the imaging performance of the MityCCD- H11501 family of cameras is included below. This family of cameras utilizes sensors from the Hamamatsu S11501 family of CCDs. Detailed datasheets regarding the sensor performance curves for sensitivity, well depth, quantum efficiency and dark current, etc. may be located on the manufacturer's website [1].

## PERFORMANCE

	Min	Typical	Max	Units
Active Pixels	-	1024x122	-	H x V
Pixel Size	-	24 x 24	-	W x H ; $\mu\text{m}$
Imaging Area	-	24.56 x 2.92	-	W x H ; mm
Gain, Setting 1 <sup>2</sup>		4.7		e <sup>-</sup> per count
Gain, Setting 2 <sup>2</sup>		14.2		e <sup>-</sup> per count
ADC resolution	-	16	-	bits
Readout Noise @ 500 kHz, Gain 1 / 2	-	12 / 22	18 / 30	e <sup>-</sup>
Dynamic Range, Gain 1 / 2	-	27K / 44K	-	
Readout Rate <sup>1</sup>	20	493	1000	kHz
Full Frame Rate	-	3	-	Frames / s
CCD Binned Frame Rate <sup>4</sup>	-	200	-	Frames / s
USB Link Throughput <sup>3</sup>	-	13,000	-	Kbytes / s
Ethernet Link Throughput <sup>3</sup>	-	1,000	-	Kbytes / s
Cooling capability below ambient	35	40	-	$^{\circ}\text{C}$
Power Utilization <sup>5</sup>	8	21	31	Watts
Power Input <sup>5</sup>	12	18	24	V DC

Table 1: MityCCD-H11501 Performance

	Typical	Units
Pixel Well Depth, typical	320	k e <sup>-</sup> / pixel
Readout Well Depth, typical (for binning)	1000	k e <sup>-</sup> / pixel
Dark Current @ -15 $^{\circ}\text{C}$	1.5	e <sup>-</sup> / pixel / s

Table 2: S11501 Electrical and Optical Characteristics

### Notes:

1 – The Readout Rate in a MityCCD stock camera is 493 KHz. The readout rate may be customized for user specific applications, please contact Critical Link, LLC, for details.

2 – The MityCCD cameras offset two gain settings, which are user configured via a software setting.

3 – Throughput rates assume a back-end PC capable of accepting the data rates provided by the camera.

4 – Assumes Full Vertical Binning within the CCD down to 1 output row using USB interface

5 – The MityCCD camera must be powered by the MityCCD-PS power supply assembly, which uses a 12-24 DC input in order to generate all necessary voltages to run the camera. The 8 Watt minimum power utilization represents a camera with no TE cooling enabled.

### QUANTUM EFFICIENCY

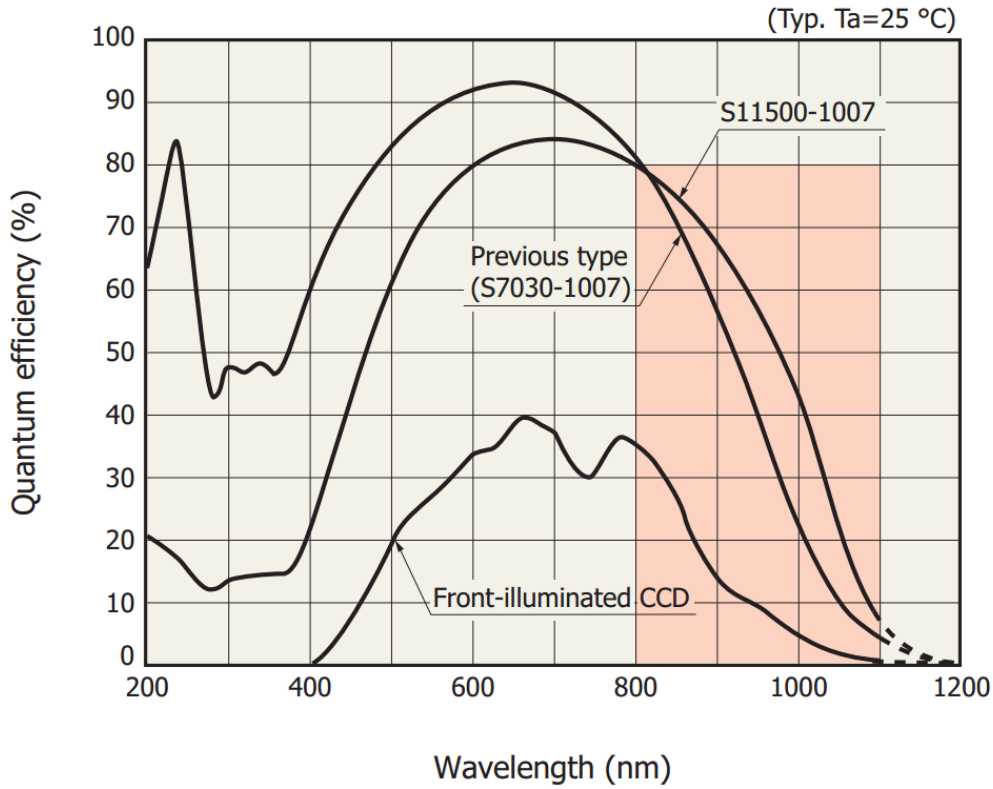

Figure 3: Spectral Response

### OPERATING AND STORAGE CONDITIONS

Ambient Temperature Range	0 °C to 50 °C
Humidity	< 80%, Non-Condensing
Storage Temperature Range	-40 °C to 65 °C

Table 3: MityCCD-H11501 Operating and Storage Conditions

## ORDERING INFORMATION

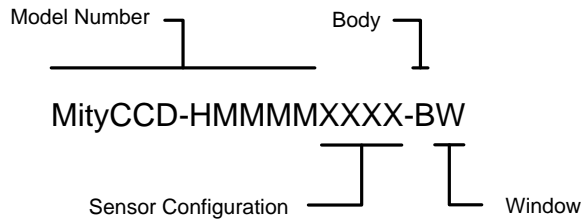

Model Number	Description
MityCCD-H11501	Back-Illuminated, IR Enhanced

Sensor Config.	Description
1007	1024x122

Body	Description
B	Open Frame – No Flange required
C	Reserved
D	Enclosed Body
E	Reserved

Window	Description
S	AR-coated Sapphire Window

### Additional Notes:

1. A MityCCD-H11501 camera also requires a power supply package and a flange package that can be ordered separately. For more information contact Critical Link, LLC for details.
2. A MityCCD-H11501 camera also requires a software package. For more information contact Critical Link, LLC for details.
3. A MityCCD-H11501 camera can be ordered with optional accessories. For more information contact Critical Link, LLC for details.

## EXTERNAL DIMENSIONS

Unless otherwise noted, all dimensions are in mm [inches].

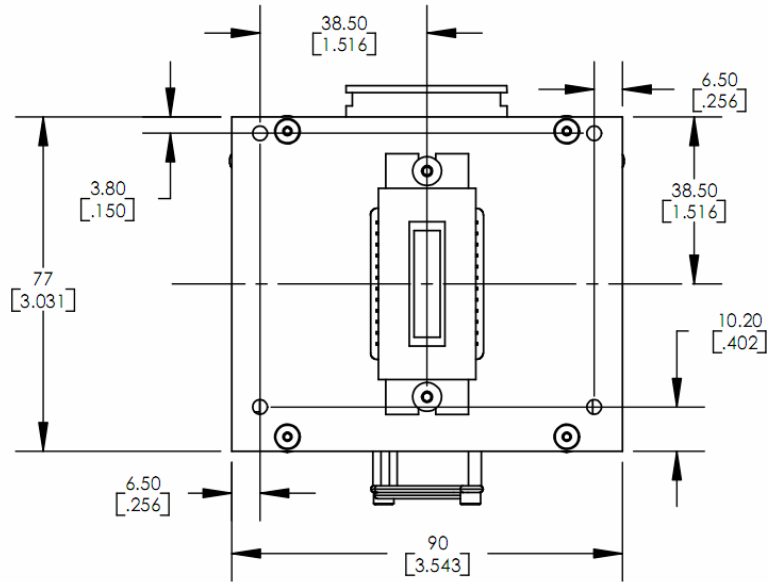

Figure 4: Open Frame Body (Type B) – Front View

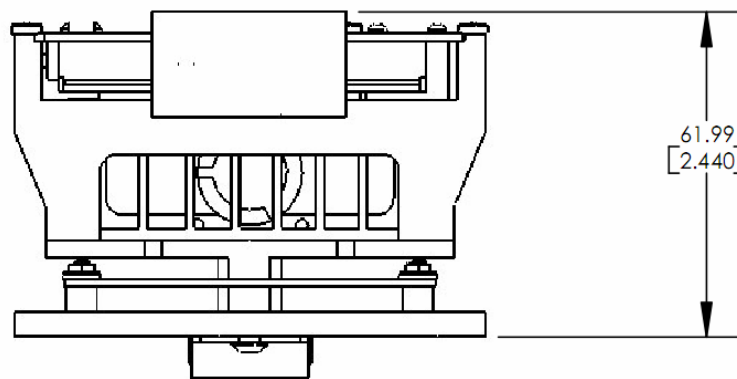

Figure 5: Open Frame Body (Type B) – Top View

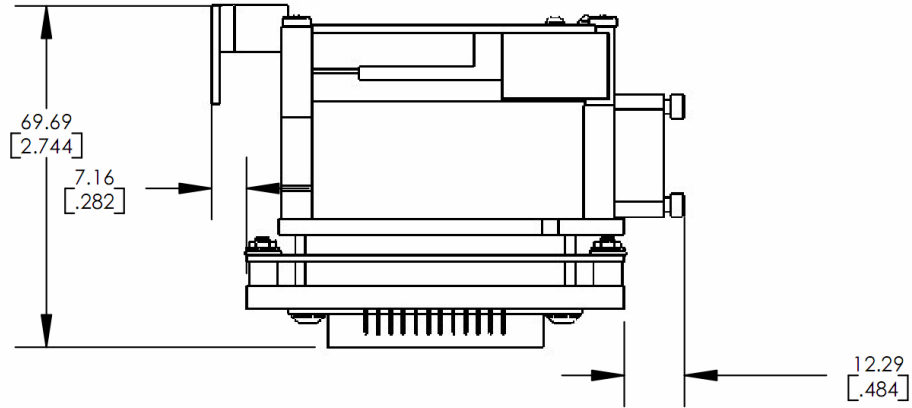

Figure 6: Open Frame Body (Type B) - Side View

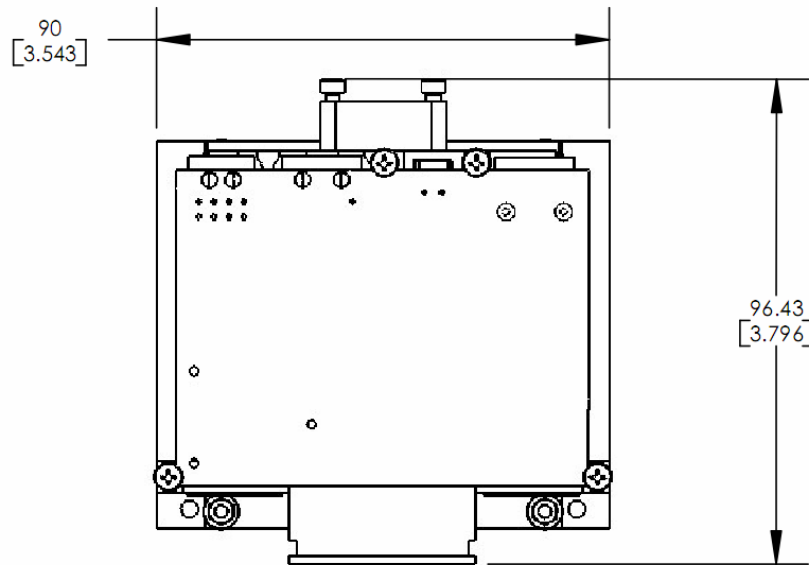
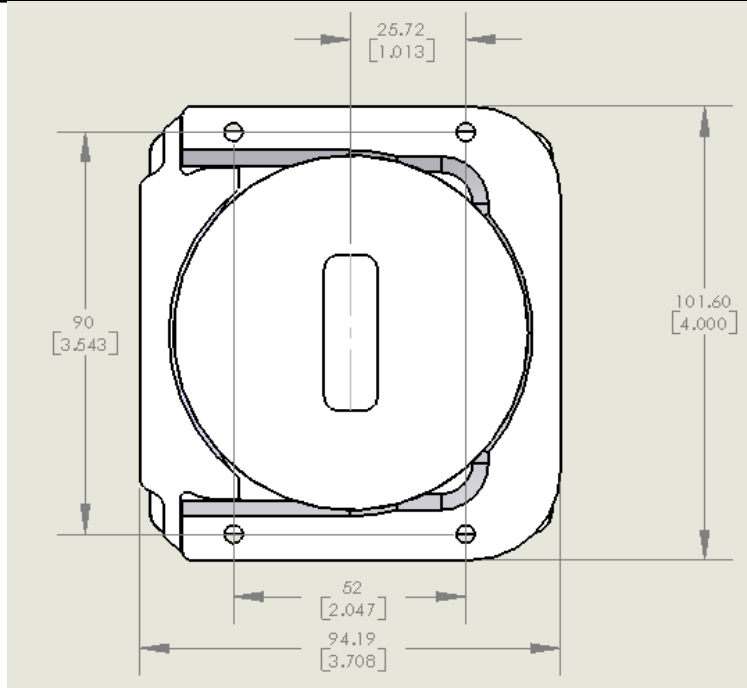
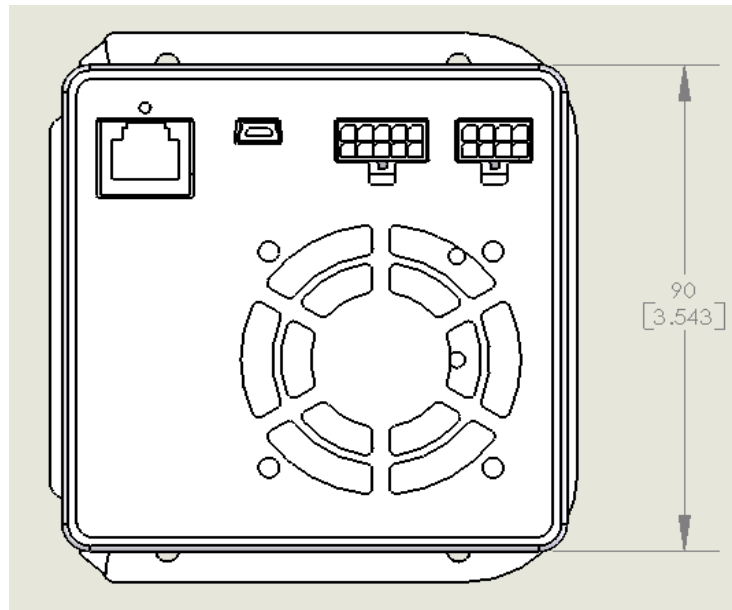

Figure 7: Open Frame Body (Type B) - Back View



**Figure 8: Enclosed Body (Type D) with Split Flange (Type C) – Front View**



**Figure 9: Enclosed Body (Type D) with Split Flange (Type C) - Back View**

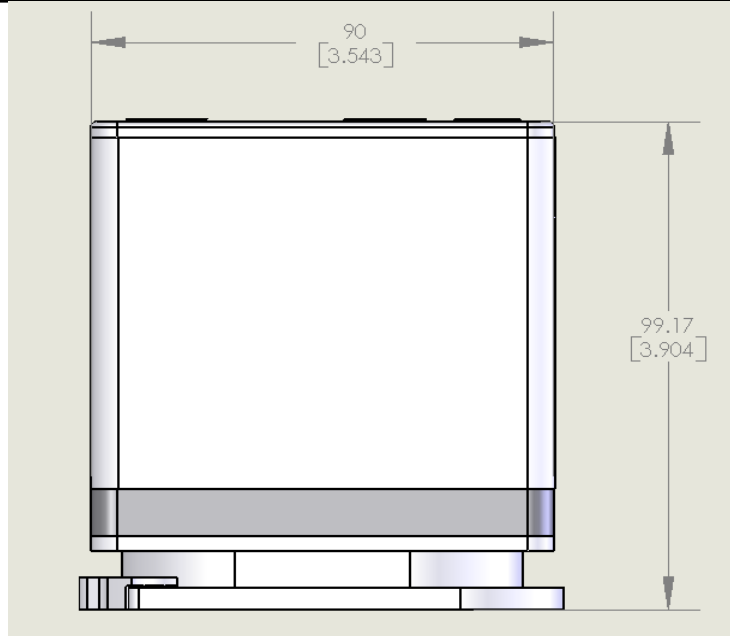

Figure 10: Enclosed Body (Type D) with Split Flange (Type C) - Top View



## ELECTRICAL CONNECTIONS

In addition to industry standard Mini USB and 10/100 Mbit based Ethernet RJ-45 communications interface jacks, the MityCCD also provides the following interface connectors.

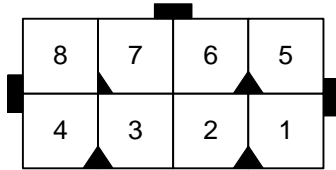

Figure 11: Power Connector <sup>1</sup> - Rear View

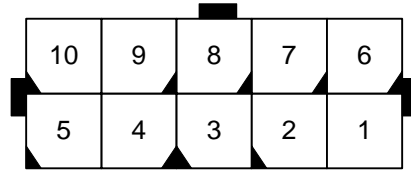

Figure 12: GPIO Connector <sup>2</sup> - Rear View

Pin	I/O	Description
1	O	TE Cooler Control
2	I	TE Cooler -V Rtn
3	-	GND
4	I	+6 V (1 Amp Max)
5	I	TE Cooler +V In (7 V at 2 Amps Max)
6	I	+15 V (0.3 Amp Max)
7	I	+32 V (0.04 Amp Max)
8	I	-9 V (0.2 Amp Max)

Pin	I/O	Description
1	I/O	General Purpose TTL I/O 3
2	I/O	General Purpose TTL I/O 1
3	O	+5 VD (800 mA Max)
4	I	RS232 RX
5	-	GND
6	-	GND
7	I/O	General Purpose TTL I/O 2
8	I/O	General Purpose TTL I/O 0
9	-	GND
10	O	RS232 TX

**Notes:**

1 – Mating connector is Mfg part# 43025-0800. Please contact Critical Link, LLC for details.

2 – Mating connector is Mfg part # 43025-1000. Please contact Critical Link, LLC for details.

## REFERENCE

- [1] Hamamatsu Photonics K.K., Solid State Division, "IR-enhanced CCD area image sensor S11500-1007," Aug 2012  
[http://www.hamamatsu.com/resources/pdf/ssd/s11500-1007\\_kmpd1125e.pdf](http://www.hamamatsu.com/resources/pdf/ssd/s11500-1007_kmpd1125e.pdf)