

FEATURES

- High-performance ams CMV50000 sensor
 - Pixel: 4.6 μ m 8T Global Shutter with true CDS
 - High Resolution: 47.5Mp, 7920(H) x 6004(V)
 - High Speed: 30fps*
 - Low noise: 8.8e-
 - High Dynamic Range: 64dB
 - High Sensitivity: QE = 60%
 - High Full Well Capacity: 14500e (binning: 58000e)
 - Optical Format: 35mm Full Frame
 - Output: 12bit
 - On-chip offset and noise correction
- Intel Arria 10 SoC Processing
 - Dual Core A9 ARM
 - FPGA Fabric up to 480K Logic Elements
 - Open architecture for custom programming
- Interface Options
 - AIA U3V (USB 3.0 Vision)
 - HDMI Preview
- Programmable General Purpose I/O
 - 4 External FPGA GPIO Pins
 - 3 Opto-Isolated Input Pins
 - Use as trigger / exposure inputs



Figure 1: MityCAM-C50000

APPLICATIONS

- Machine Vision
- Industrial Inspection
- Document Scanning
- Aerial Mapping and Surveillance
- Video/Broadcast

DESCRIPTION

The MityCAM-C50000 from Critical Link features a high-performance CMOS image sensor from ams. The camera is available with a 47.5MP CMV50000 sensor, AIA USB 3.0 Vision Interface (U3V), and an HDMI preview output interface.

Combined with Critical Link's software tools designed for our Arria 10 based processor card, the MityCAM-C50000 makes sensor evaluation and product integration quick and easy. The MityCAM features a standard Nikon F mount lens. Critical Link also supports a board set version of the camera for customers designing their own mechanicals or managing other integrations; contact us via info@criticallink.com for more details.

Detailed datasheets regarding the sensor performance curves for sensitivity, well depth, quantum efficiency and dark current, etc. may be located on the manufacturer's website [1] and within the CMV50000 datasheet [2].

*continuous output rates limited to USB 3.1 Gen 1 capacity, bursting to RAM is supported. Frame rates can be increase using reduced or multi-ROI features of the sensor.

MityCAM is a trademark of Critical Link, LLC.

The MityCAM-C50000 electronics leverage a modular design that allows Critical Link to quickly develop support for custom interface designs. The block diagram in Figure 2 shows the structure of the MityCAM-C50000.

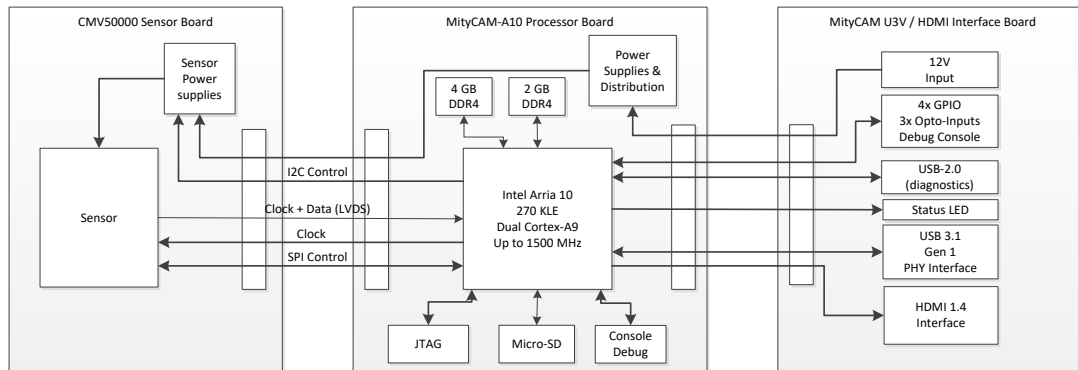

Figure 2: MityCAM-C50000 Electronics Block Diagram

TECHNICAL SPECIFICATIONS

A summary of the imaging performance of the MityCAM-C50000 family is included below.

PERFORMANCE

	Min	Typical	Max	Units
Active Pixels	-	7920 x 6004	-	H x V
Pixel Size	-	4.6 x 4.6	-	W x H ; μm
Imaging Area	-	36.5 x 27.6	-	W x H ; mm
Dark current (@60 °C die temp)	-	66.2 ¹	-	e ⁻ /pixel/sec
ADC resolution	-	12	-	bits
Normal Mode Read-out Noise (@30 fps)	-	8.8	-	e ⁻
Binned Mode Read-out Noise	-	22	-	
Mono QE @ 450nm	-	58	-	%
@ 510nm	-	61	-	
@ 600nm	-	53	-	
@ 850nm	-	14.5	-	
Conversion Gain: Normal	-	0.27	-	DN / e ⁻
Binned	-	0.068	-	
Dynamic Range: Normal	-	64	-	dB
Binned	-	68	-	
Full Well Capacity: Normal	-	14500	-	e ⁻
Binned	-	58000	-	
Cooling Method		Forced Air		
Full Frame Rate	-	-	30 ²	Frames / s
Power Utilization	-	19	20	Watts
Mass (Body, no lens)		44		oz.
		1248		g
Power Input	10.8	12	13.2	V DC
1- Dark current doubles every 5.1 °C				
2- continuous frame rate limited by USB 3.0 output rate, see Readout Rates				

Table 1: MityCAM-C50000 Performance

OPERATING AND STORAGE CONDITIONS

Ambient Operating Temperature Range	0 °C to 40 °C
Humidity	<80%, Non-Condensing
Storage Temperature Range	-40 °C to 85 °C

Table 2: MityCAM-C50000 Operating and Storage Conditions

ELECTRICAL CONNECTIONS

The MityCAM-C50000 back panel is shown in Figure 3.

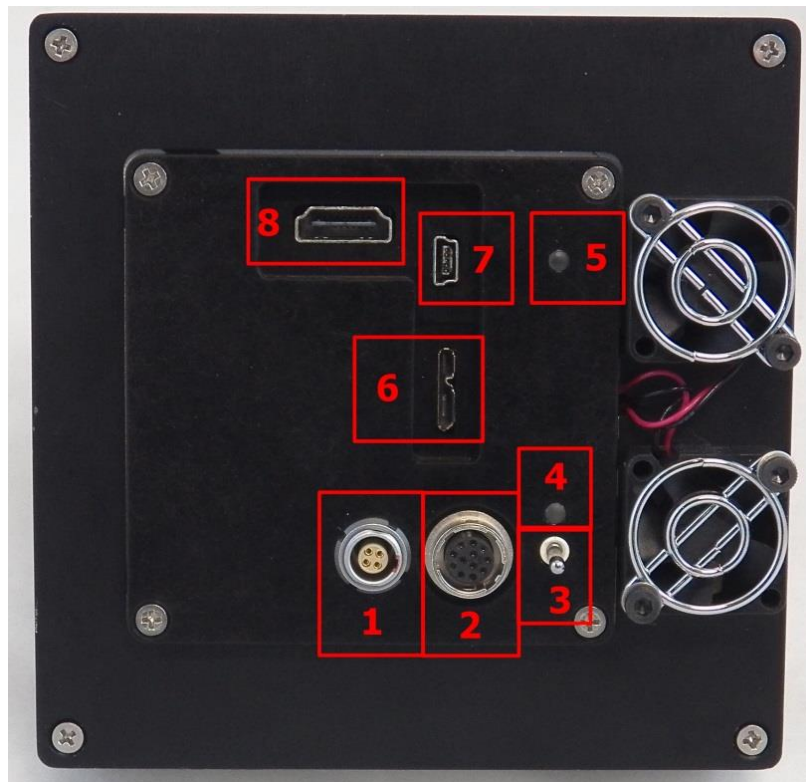

Figure 3: Input / Output Connections on Rear

The numbered connectors are defined in the list below.

1. Power Input Connector – Keyed
2. GPIO and Serial Connector – Keyed
3. Power Switch
4. Power Good Indicator LED
5. Camera Status LED
 - a. Green – Ready to Capture Images
 - b. Blinking Blue – Capturing Images
 - c. Red – Error State
6. USB 3.0 Connector – PC Image Capture Interface
7. USB 2.0 Connector – Not Utilized
8. HDMI Connector – Output to Monitor

Power Input

The MityCAM-C50000 has a single power input connector on the rear of the units. This 4-pin LEMO ECG.0B.304.CLN connector utilizes 2-positive power input pins and 2-ground connections as shown in Figure 4 and Table 3 below. Each kit includes an AC to 12V DC (3A) power adapter.

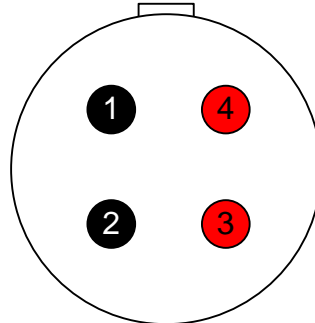

Figure 4: P200 Power Input Connector

Pin	Type	Description
1	GND	Ground
2	GND	Ground
3	PWR	+12 VDC
4	PWR	+12 VDC

Table 3: P200 Input Power Connector Pin-Out (P200)

Note that over voltage, under-voltage and reverse polarity protection is provided within the kit however care should be taken if a non-standard adapter is used. The mating connector is a LEMO FGG.0B.304.CLAD52 or similar connector.

USB 2.0 Interface

The MityCAM-C50000 features a standard Mini-B type USB connector on the rear of the unit. This interface is used for development purposes (e.g., software and firmware updates, low level access to camera functions). This interface presents a standard RNDIS ethernet interface when connected to a host PC.

General Purpose IO

Four general purpose FPGA IO pins, 3 optically isolated inputs, the Arria 10 HPS console signals, and a power shutdown request line are made available for the user via the GPIO connector, HR10-10R-12SA(73), on the rear of the unit. The GPIO's and console signals utilize 1.8V CMOS logic levels and are ESD protected to standards supporting IEC61000-4-3 and 61000-4-4. Table 4 and Figure 5 show the pin-out for the GPIO interface connector. The opto-isolated inputs support an "on" state input voltage between 2-24 V and require a minimum of 2 mA of current. The off must be < 1.5V and below 1.5 volts. Note that the opti-isolated input ground/return (pin 9) is not tied to digital ground (pin 6).

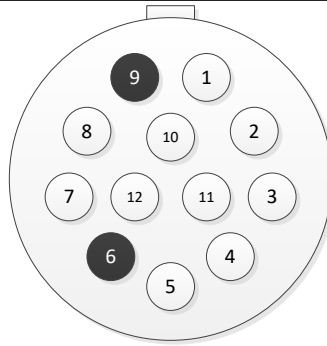

Figure 5: GPIO Interface Connector Pin Out (P201)

Pin	Type	Description	Notes
1	I/O	IO 0 – 1.8V CMOS Logic Level (supports external trigger)	Connected to pin E21 on FPGA.
2	I/O	IO 1 – 1.8V CMOS Logic Level	Connected to pin F21 on FPGA.
3	I/O	IO 2 – 1.8V CMOS Logic Level	Connected to pin C22 on FPGA.
4	I/O	IO 3 – 1.8V CMOS Logic Level	Connected to pin G23 on FPGA.
5	I	Camera shutdown, short to GND to turn off camera, otherwise leave unconnected.	
6	GND	Ground	
7	O	1.8V Serial Console Output	Connected to pin XX on FPGA.
8	I	1.8V Serial Console Input	Connected to pin XX on FPGA.
9	ISO_GND	Reference / Return for Isolated input currents.	
10	I	Opto-isolated Input 0	Connected to pin E22 on FPGA.
11	I	Opto-isolated Input 1	Connected to pin F22 on FPGA.
12	I	Opto-isolated Input 2	Connected to pin D22 on FPGA.

Table 4: GPIO Connector Pin-Out (P201)

The mating connector is a HR10A-10P-12P(73) or similar connector.

IO pins can be driven as outputs using software interface commands, they can also be read as inputs. The embedded ARM software on the camera can be customized to capture transitions for asynchronous processing, if desired. In addition, Pin IO 0 can be used for external frame request signaling (hardware frame triggering). Pin IO 1 can be used for external exposure control signaling (hardware exposure control).

The console port signals on the connector support operation at 115200 Baud, 8 bits, 1 stop bit, no parity, with no flow control. This port may be used to monitor the boot progress and access the linux console for diagnostics purposes. For basic operation, using this port is not required.

Cooling

The MityCAM-C50000 features two integrated 25mm fans for the body with an integrated heat sink via the case body. When installed the fan can be enabled or disabled through the I2C based LED status light and fan controller. It can be accessed on I2C bus 1 at address 1100 010.

If the board set only version is utilized in your custom design proper cooling measures must be taken to ensure that the imaging sensor does not exceed the specified maximum temperature of Table 2.

Read-out rates

The maximum continuous read-out rates below are valid when the CMV50000 sensor is configured to output in 12-bit mode with an appropriately configured clock. See Table 5 for typical read out rates.

Table 5 Typical Read Out Rates

Image Capture Size	USB 3.0 U3V Interface	HDMI Preview
47.5 Mpixels x 12 bits	4 fps	30 fps
47.5 Mpixels x 8 bits	6 fps	30 fps

Sensor Bit Depth

The MityCAM-C50000 standard offering configures the ams CMV50000 sensor to output pixel data using 12 bits per pixel. To support increased output rates, the MityCAM-C50000 can be configured to truncate the input pixel depth to 8 bits.

Burst Capture

Due to limitations of U3V, the camera cannot continuously capture at the highest resolution and output at a full bit-depth. The camera can capture using the highest possible sensor clock first into RAM and then stream the data out at a slower rate. In this mode the camera evaluation kit allows the user to capture 30 full-resolution frames at an effective frame-rate of 30 fps.

HDMI / Preview

The EVK supports display of color or pseudo grayscale output on HDMI monitors at 4K UHD resolutions or at 1080P HD resolutions. Users may configure the effective region of interest to display on the monitor. The EVK will perform the necessary scaling to fit the requested region to the monitor resolution.

EXTERNAL DIMENSIONS

For customers desiring a complete camera assembly, Critical Link offers enclosed body models that can be used for final application development as shown in Figure 6.



Figure 6: Camera Option Shown with Example Lens and Tripod, Side View

See Figure 7 and Figure 8 for camera dimensions. Measurement are in inch units.

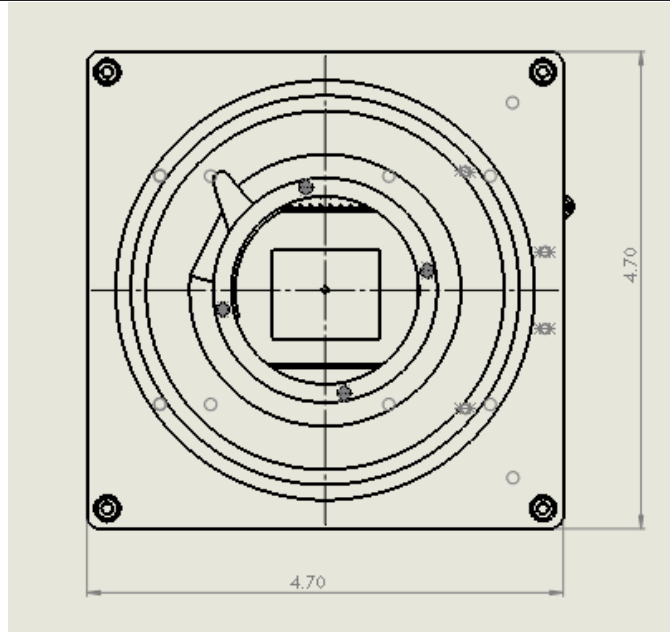

Figure 7: Camera Body with F Mount Lens Mount - Front View

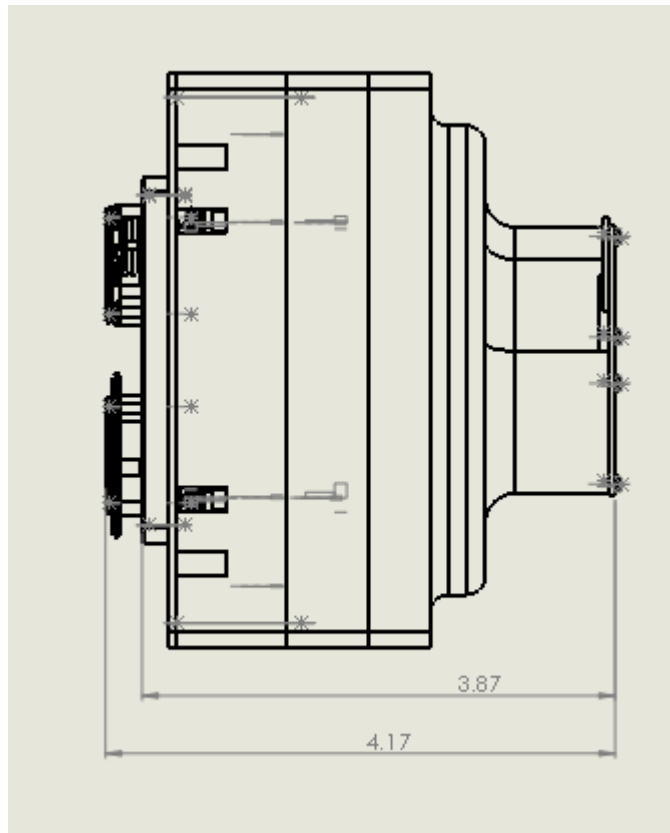

Figure 8: Camera Body with F Mount Lens Mount - Side View

EXTERNAL DIMENSIONS – BOARD SET

Critical Link can provide board set solutions if the compact body mechanical arrangement does not meet your application needs. Board sets do not include some features of the base offering. Please contact Critical Link via info@criticallink.com for detailed drawings for a MityCAM-C50000 board set.

ORDERING INFORMATION

Table 6 lists the standard configurations for the MityCAM-C50000. For shipping status, availability, and lead time of these or other configurations please contact Critical Link via info@criticallink.com.

Table 7 provides an accessory kit part number for the MityCAM-C50000. This kit is required when evaluating the sensor or doing development, and is compatible with the models listed in Table 6. It is not required for cameras that are being integrated into a working design.

Table 6: Standard Model Numbers

Model	Sensor	High Speed Interface Option	Color/ Mono	Enclosure Type
C50000-UM-C-S	CMV50000	USB 3 + HDMI	Mono	Body
C50000-UC-C-S	CMV50000	USB 3 + HDMI	Color	Body
C50000-UC-X-S	CMV50000	USB 3 + HDMI	Color	Board Set

Table 7: MityCAM-C50000 Accessory Kit

Part Number	Kit Contents
80-001150	Nikon 50mm f/1.8 Lens Tripod I/O Cable USB 3 Cable HDMI Cable Power Supply

REVISION HISTORY

Table 9: Revision History

Date	Rev	Change Description
04-June-18	A	Initial preliminary revision / Draft
28-Nov-18	B	Added information email. Updated features.
20-Sep-19	C	Updated Table 7, Accessory Kit Contents

REFERENCES

- [1] <https://ams.com/cm50000>
- [2] CMV50000, “CMV50000_DS000522_1-00.pdf”, Feb 23 2018.