

FEATURES

- 1 RS-232 Compliant Output
- 1 RS-232 Compliant Input
- RS232 Protocol
 - Up to 115,200 baud rate
- On-Board TX/RX Output Swapping
 - Resistor changeable
- Compatible with MitySOM/MityDSP based Development Kits from Critical Link

Applications

- External Hardware Interfacing
- Embedded Instrumentation



(1.8" x 1.2" – actual size)

DESCRIPTION

The RS232 Expansion Kit is compatible with Critical Link’s line of MitySOM/MityDSP based development kits; one is required to interface with this expansion kit. All MitySOM/MityDSP based System on Modules support RS232, see Table 1 for details concerning SoM support.

Table 1: Critical Link SoM RS232 Support

Module Type	RS232 Support
MitySOM-1810	Yes
MitySOM-1810F	Yes
MityDSP-L138	Yes
MityDSP-L138F	Yes
MitySOM-1808	Yes
MitySOM-1808F	Yes
MitySOM-3359	Yes

RS232 Description

The RS232 Expansion Kit provides standard serial interface at data rates up to 115,200 baud that can be seamlessly added to your design. The serial interface is routed to one of the UART ports of the MitySOM/MityDSP through the UART Expansion Header on a MitySOM/MityDSP based Development Kit.

Linux Driver and API examples are available.

The level conversion from the input CMOS levels to the output RS232 levels is done by a MAX3232IDR Line Driver/Receiver. This part offers two receivers and drivers but the second set is unused on this board.

Through the use of 4 resistors the RS232 Expansion Kit can alter which output pins are used for TX and RX depending if a null-modem or standard cable type is necessary. See Table 4 for details.

The electrical interface between the RS232 Expansion Kit and MitySOM/MityDSP based Development Kit is provided via the 10-pin shrouded header described in Table 2.

The electrical interface between the RS232 Expansion Kit and an external device is provided via the 9-pin DB9 connector described in Table 3.

Please reference your specific MitySOM/MityDSP Based Development Kit documentation to determine which connector to use for the RS232 Expansion Kit.

RS232 Expansion Kit Pinouts

Table 2 shows the input 10-pin shrouded header pin out for the RS232 Expansion Kit input header. This connector, J501, is the interface to the MitySOM/MityDSP based development kit.

Table 2: PROFIBUS/RS485 Expansion Kit 10-Pin Header Pin Out

Pin	Name	Type	Note
1	ENB	3.3V CMOS	Unused - Input to Expansion
2	RXD	3.3V CMOS	Output from Expansion
3	+3.3V	Power	20mA max
4	Reserved	-	
5	Reserved	-	
6	TXD	3.3V CMOS	Input to Expansion
7	GND	Power	
8	Reserved	-	
9	Reserved	-	
10	Reserved	-	

Table 3 shows the output 9-pin DB9 connector, J500, to interface with an outside RS232 device.

Table 3: RS232 Expansion Kit 9-Pin DB9 Pin Out

Pin	Name	Type	Note
1	Reserved	-	
2	RS232_RX	RS232	Data signal - See Note 1 below
3	RS232_TX	RS232	Data signal - See Note 1 below
4	Reserved	-	
5	GND	Power	
6	Reserved	-	
7	Reserved	-	
8	Reserved	-	
9	Reserved	-	

Note 1: The RX and TX output pins can be swapped on the expansion board by changing R401/R403 and R400/R402 for RX and TX respectively, see schematic and Table 4 for details.

Table 4: RS232 Output Resistor Settings

Output Pins	R400	R401	R402	R403
RX Pin 2 TX Pin 3	-	-	Populated	Populated
RX Pin 3 TX Pin 2	Populated	Populated	-	-

ABSOLUTE MAXIMUM RATINGS

If Military/Aerospace specified cards are required, please contact the Critical Link Sales Office or unit Distributors for availability and specifications.

Maximum Supply Voltage, Vcc 3.4 V

Storage Temperature Range -65 to 80C

OPERATING CONDITIONS

Commercial 0 to 70C
Temperature Range
Humidity 0 to 95%
Non-condensing

ELECTRICAL CHARACTERISTICS

Symbol	Parameter	Conditions	Min	Typ	Max	Units
Vcc	Voltage supply, 3.3 volt input.			3.3	3.4	Volts
Icc	Quiescent Current draw, 3.3 volt input			TBD	TBD	Milliamps

ORDERING INFORMATION

The following table lists the orderable module configurations. For shipping status, availability, and lead time of these or other configurations please contact your Critical Link representative.

The necessary 10-pin cable to connect to a MitySOM/MityDSP based Development Kit is provided with each RS232 Expansion Kit.

Table 5: Orderable Model Numbers

Model	Protocol(s) Supported
80-000541	RS232

MECHANICAL INTERFACE

A mechanical outline of the RS232 Expansion Board is illustrated below.

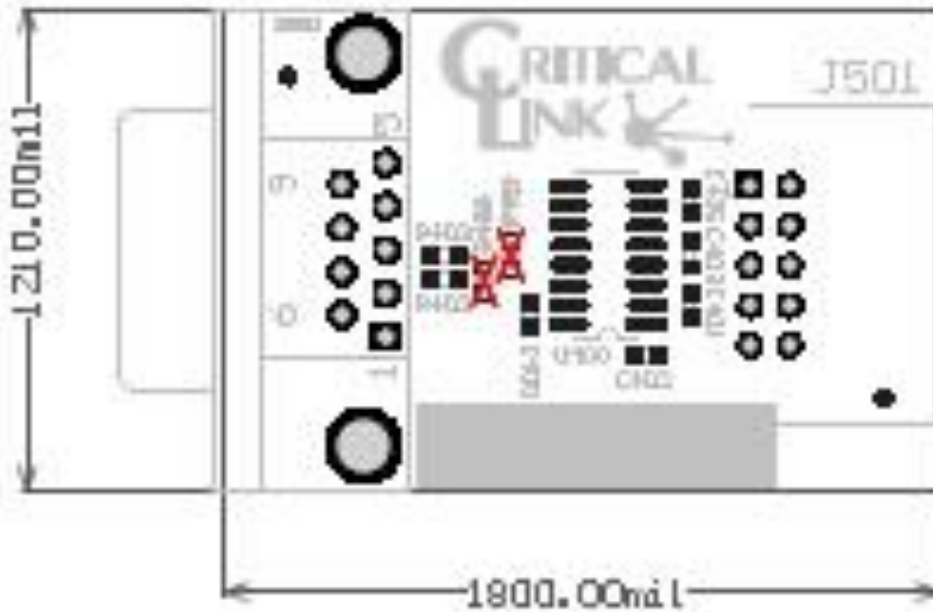

Figure 1: Dimensions 1.8" x 1.2"

REVISION HISTORY

Date	Change Description
10-OCT-2012	Initial revision.
17-OCT-2012	Update part number
5-MAR-2014	Update MitySOM product name